

1 2 3 4 5 6

A

A

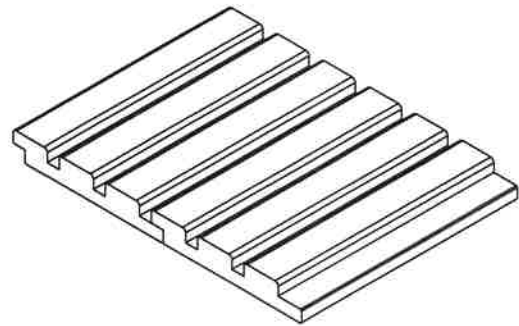
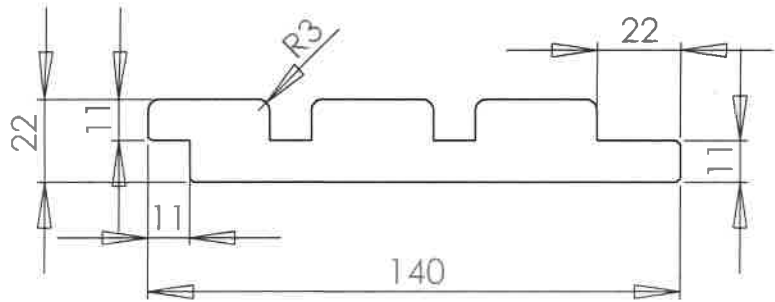

B

B

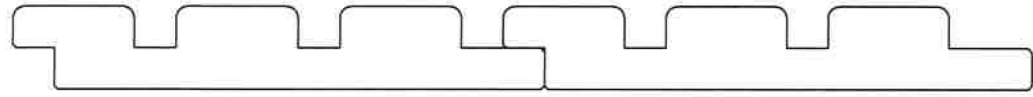

C

C

D

| | | | | | | | | | |
|---|-----------|---------|--|-----------------------------------|-----------|----------------------|--|--------------|--|
| UNLESS OTHERWISE SPECIFIED: DIMENSIONS ARE IN MILLIMETERS SURFACE FINISH: TOLERANCES: LINEAR: ANGULAR: | | FINISH: | | DEBUR AND BREAK SHARP EDGES | | DO NOT SCALE DRAWING | | REVISION | |
| NAME | SIGNATURE | DATE | | | | TITLE: | | | |
| DRAWN | | | | | | | | | |
| CHK'D | | | | | | | | | |
| APPV'D | | | | | | | | | |
| MFG | | | | | | | | | |
| Q.A | | | | | MATERIAL: | DWG NO. | | | |
| | | | | | | | | | |
| | | | | | | | | | |
| | | | | | WEIGHT: | SCALE:1:2 | | SHEET 1 OF 1 | |

A4

1

2

WEIGHT:

SCALE:1:2

SHEET 1 OF 1